

33502616 型式:K11320C
(12寸チヤク)

4 基本参数及主要性能指标 Basic parameters and main features

4.1 短圆柱型K11、K11 (QT)、K11 (G) 卡盘基本参数见图2、表2，主要性能指标见表3。

4.1 The general parameters of short-cylindrical chucks for K11, K11(QT) and K11(G) chucks, See. Fig. 2, table 2 and main ability target See. table 3.

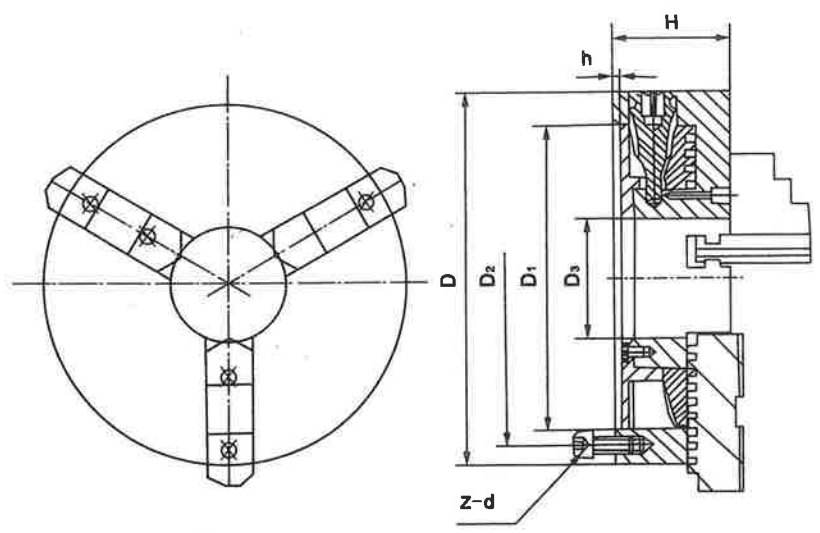

图 2 (Fig.2)

表 2 (table 2)

规格 Size D	D ₁	D ₂	D ₃	H	h	z-d
80	55	66	16	50	3.5	3-M6
100	72	84	22	55	3.5	3-M8
125	95	108	30	58	4	3-M8
130	100	115	30	60	3.5	3-M8
160	130	142	40	65	5	3-M8
160A	130	142	40	65	5	3-M8
165	130	145	40	66.5	4.5	3-M8
190	155	172	55	75	5	3-M10
200	165	180	65	75	5	3-M10
200C	165	180	65	75	5	3-M10
200A	165	180	65	75	5	3-M10
240	195	215	70	80	8	3-M12
240C	195	215	70	80	8	3-M12
250	206	226	80	80	5	3-M12
250C	206	226	80	80	5	3-M12
250A	206	226	80	80	5	3-M12
315	260	285	100	90	6	3-M16
315A	260	285	100	90	6	3-M16
320	270	290	100	95	11	3-M16
320C	270	290	100	95	11	3-M16
325	272	296	100	96	12	3-M16
325C	272	296	100	96	12	3-M16
325A	272	296	100	96	12	3-M16
380	325	350	135	98	6	3-M16
380C	325	350	135	98	6	3-M16
380A	325	350	135	98	6	3-M16
400	340	368	138	100	6	3-M16
400D	340	368	138	100	6	3-M16
500	440	465	210	115	6	6-M16
500D	440	465	210	115	6	6-M16
500A	440	465	210	115	6	6-M16
630	560	595	270	133.5	7	6-M16
630D	560	595	270	133.5	7	6-M16
630E	560	595	270	133.5	7	6-M16
800D	710	760	385	161	8.5	6-M20
800E	710	760	385	161	8.5	6-M20